

Noise and Gain of the RCA-8056 Nuvistor Triode at 200 Megacycles

This Note provides information on the noise figure and gain of the RCA-8056 low-voltage nuvistor triode under noise-matched conditions at 200 megacycles over a range of practical values of plate current and voltage. When used in conjunction with values of other characteristics given in the technical data for these types, this information makes it possible to estimate the performance of these tubes under small-signal conditions at any operating point with reasonable accuracy.

Design Features of the 8056

The 8056 is a low- μ high-transconductance triode of nuvistor design, featuring small size and light weight, especially developed for operation at plate-supply voltages of 12 to 30 volts. The cylindrical active elements of the tube are mounted coaxially on ceramic base wafers. Each element is supported by a tripod arrangement of leads which extend through the base wafer. One lead of each set is used as the external connector. Sections of the shell extending beyond the base wafer serve as indexing lugs for socket insertion. These indexing lugs also provide protection for the tube leads and can be used to ground the metal shell through the socket so that the use of a tube shield is unnecessary.

Noise Figure and Gain

Curves of constant noise figure and gain for the 8056 are shown in Figs. 1 and 2, respectively. These curves permit the effect of a change of operating point to be determined at a glance. In particular, the curves show how the operating point can be varied to change two parameters simultaneously in a desired direction.

For example, a tube operated at a plate voltage of 35 volts and a plate current of 11 milliamperes has a noise figure of 4.5 db and a gain of approximately 16.4 db. If it is desired to increase the gain and reduce the noise figure, the operating point should be moved to the left of the 4.5-db noise-figure curve in Fig. 1, and above the (interpolated) 16.4-db gain curve in Fig. 2. If the plate voltage is decreased to 29 volts and the plate current is increased to 13 milliamperes, the noise



figure is reduced to 4 db and the gain is increased to slightly more than 17 db.

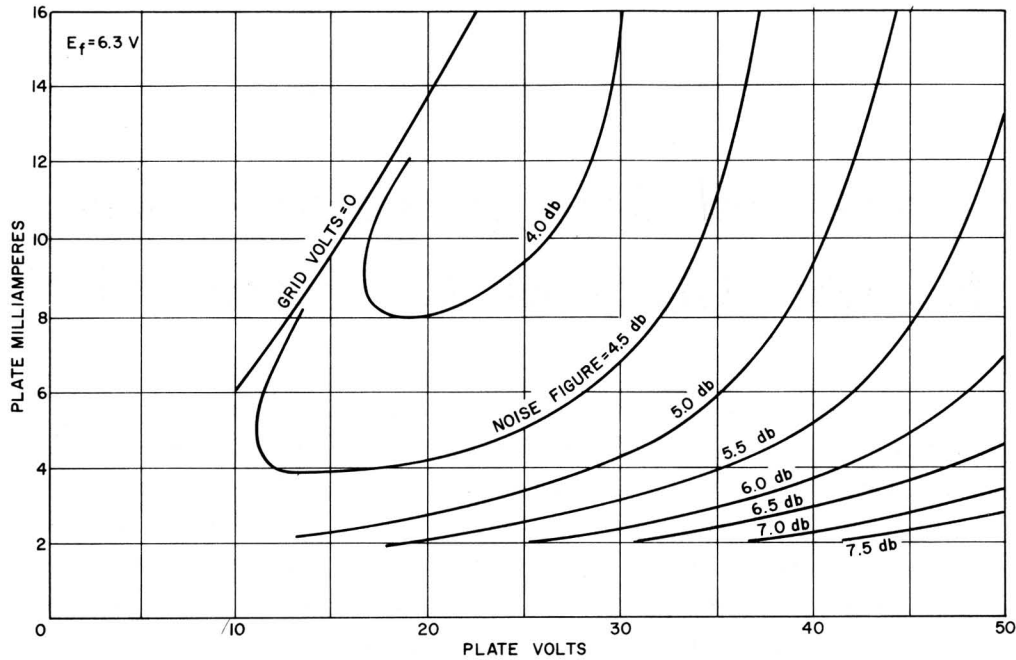

Fig. 1 - Noise figure at noise match.

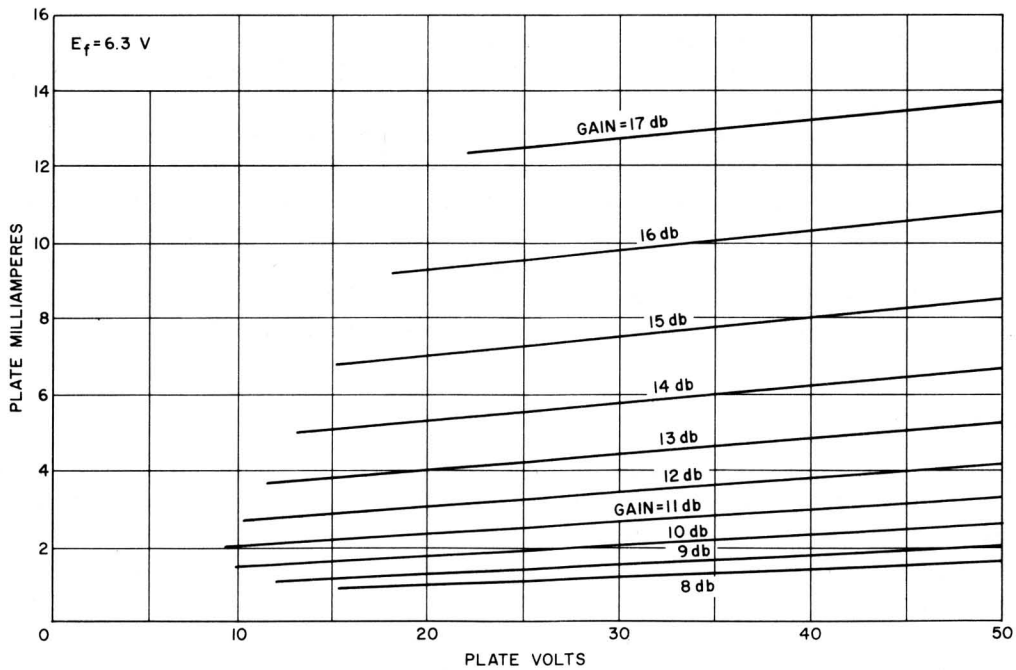

Fig. 2 - Power gain at noise match.

The optimum noise figure within the rated plate-current and dissipation limits is about 3.7 db; this value is obtained with a plate voltage of 24 volts and a plate current of 15 milliamperes. The noise figure of the 8056, therefore, is somewhat better than that of the 7586, or the 7895,



and is achieved at much lower plate voltage and dissipation with somewhat lower transconductance (gain). As a result, the 8056 is particularly useful in the input stages of mobile communications receivers.

Although the 8056 is not specifically controlled for noise, the data shown in Fig.1 represent typical noise performance.

Description of Measuring Circuit

The test circuit used for the gain and noise measurements described in this Note is shown in Fig.3. The circuit consists of a partially

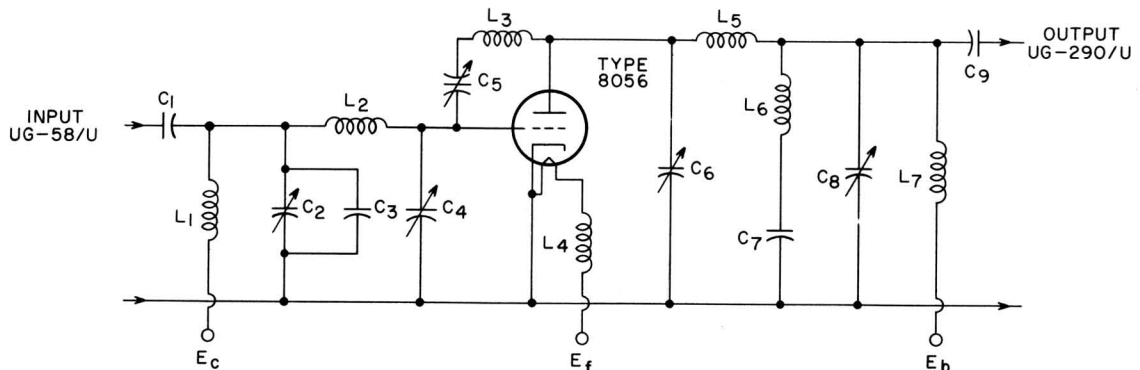

- | | |
|--|--|
| C ₁ : 2200 pf, uncoated disc ceramic, soldered directly on input connector | L ₁ , L ₄ , L ₇ : Ohmite rf choke, Z-235 |
| C ₂ : Hammarlund APC-50 | L ₂ : 1 loop of No.14 magnet wire 9 cm long, bent to form a U 2 cm wide, 1 to 2.5 cm from chassis |
| C ₃ : 22 pf, tubular ceramic | L ₃ : B & W Miniductor 3002, 5-1/2 turns |
| C ₄ : E. F. Johnson 5 M11 | L ₅ : 5 cm of No.14 magnet wire, slightly bent, 1.8 cm from chassis |
| C ₅ : E. F. Johnson 9 MB11 | L ₆ : silvered strap 0.4 cm wide, 2.5 cm long, bent to form a U 1 cm wide |
| C ₆ : E. F. Johnson 9 M11 | |
| C ₇ : 2200 pf, uncoated disc ceramic, soldered directly on chassis | |
| C ₈ : Hammarlund APC-25 | |
| C ₉ : 2200 pf, uncoated disc ceramic, soldered directly on output connector | |

Chassis 5-1/2 inches long, 4 inches wide, 1-1/2 inches deep, of 0.024-inch copper tinned on the wiring side, partitioned to the full depth 2-1/2 inches from the input wall. The partition cuts across the center of the socket and is sliced 1/16 inch into the socket. Neutralizing coil L₃ and capacitor C₄ are mounted on the grid side of the partition and partially shielded from the input circuit.

Fig.3 - Test circuit.

neutralized grounded-cathode amplifier stage which has a bandwidth of approximately 4 megacycles. The output of the amplifier is matched to a 50-ohm load through a pi network; a similar network is used to adjust the source admittance for minimum noise figure. A Hewlett-Packard Model 342-A Noise-Figure Meter and Model 343-A VHF Noise Source (diode) are used to adjust the circuit for minimum noise and also for noise measurement. An



additional amplifier having a noise figure of 6.3 db is used between the test chassis and the input of the noise-figure meter; the effect of the noise figure of this amplifier is excluded from the test results by calculation.

The test amplifier is neutralized only by use of a shunt inductance between grid and plate; as a result, the feedback conductance is not affected except by losses in the inductor itself. Because of the incomplete neutralization, the ratio of forward to reverse gain is approximately 50 db at normal plate current, and decreases to about 40 db at low plate current. However, the effect of the incomplete neutralization on noise figure and gain appears to be negligible.

Information furnished by RCA is believed to be accurate and reliable. However, no responsibility is assumed by RCA for its use; nor for any infringements of patents or other rights of third parties which may result from its use. No license is granted by implication or otherwise under any patent or patent rights of RCA.